

U-DS90W Creation Station Assembly Instructions

Contents of Hardware Pack:

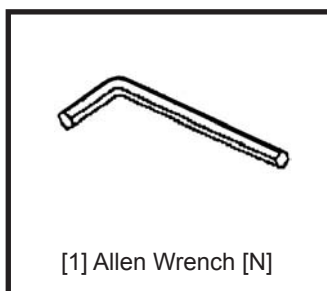
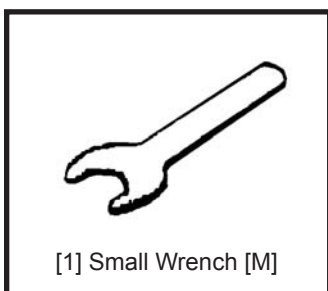
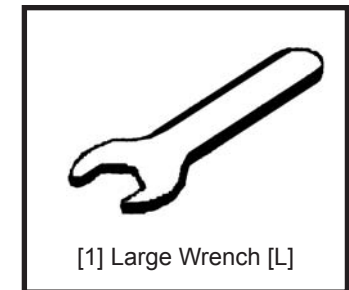
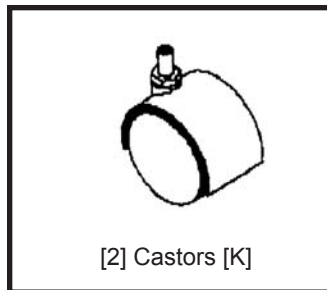
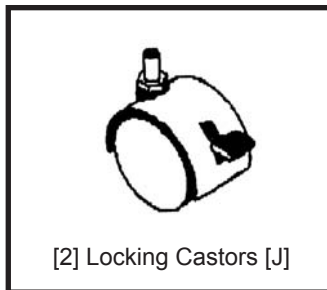
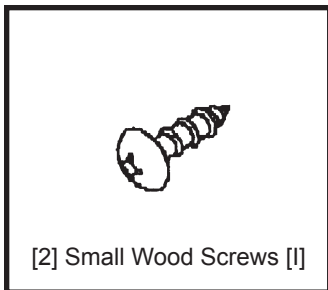
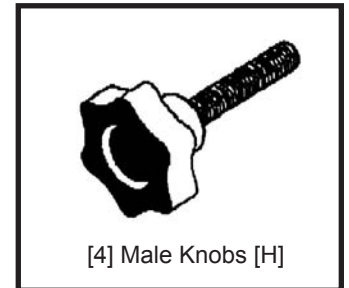
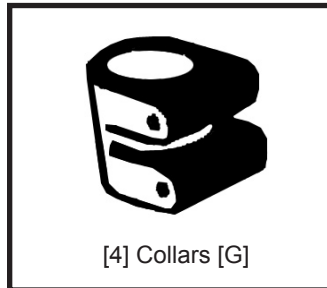
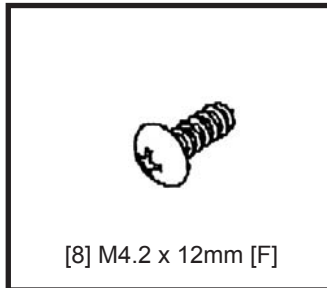
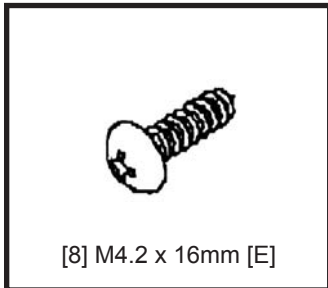
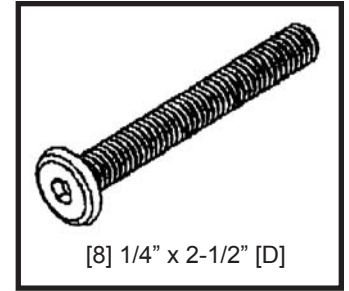
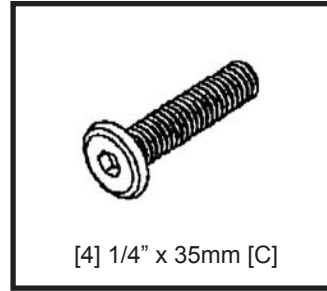
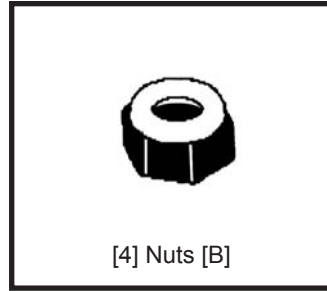
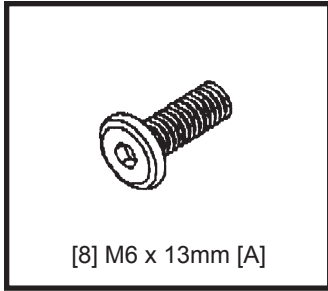

List of Hardware:

Qty	Part Description	Part Number
[8]	M6 x 35mm	[A]
[4]	Nuts	[B]
[4]	1/4" x 35mm	[C]
[8]	1/4" x 2-1/2"	[D]
[8]	M4.2 x 16mm	[E]
[8]	M4.2 x 12mm	[F]
[4]	Collars	[G]
[4]	Male Knobs	[H]
[2]	Small Wood Screws	[I]
[2]	Locking Castors	[J]
[2]	Castors	[K]
[1]	Large Wrench	[L]
[1]	Small Wrench	[M]
[1]	Allen Wrench	[N]

IMPORTANT

If you have difficulty assembling your U-DS90W Creation Station or need customer service assistance. Please call:

Martin Universal Design, Inc.
Customer Service Hot Line at
1-313-895-0700.

If you need additional parts,
it is not necessary to contact your dealer,
our Customer Service Rep. will forward them
to you immediately.

U-DS90W Creation Station Assembly Instructions

Parts List:

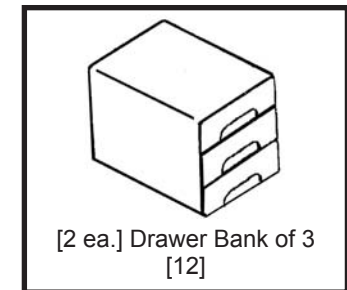
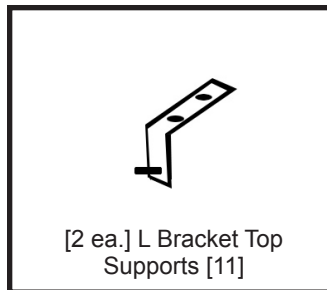
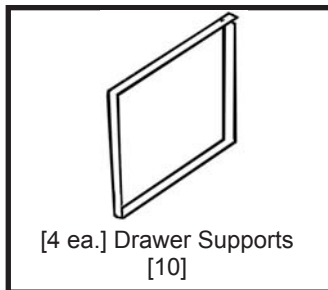
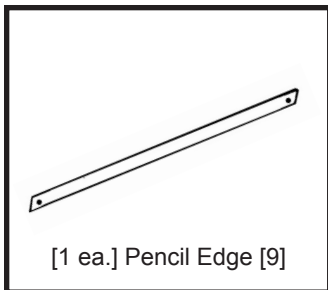
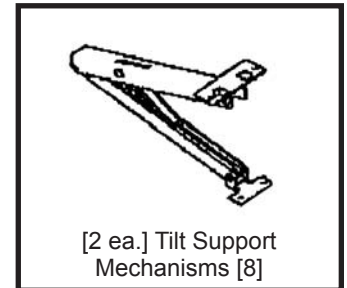
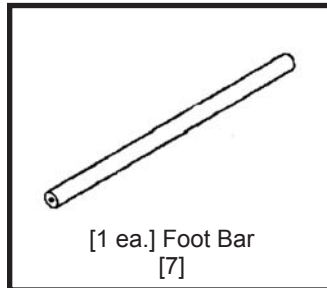
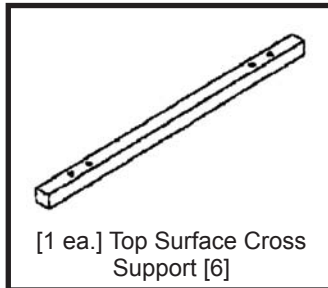
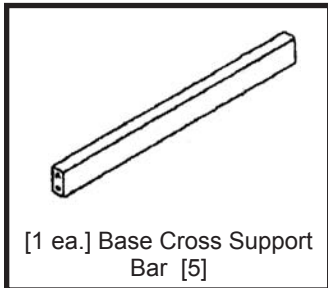
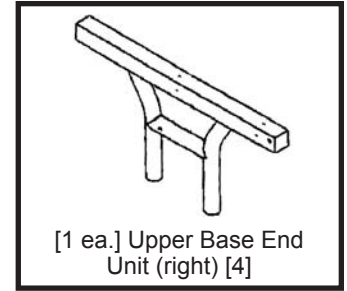
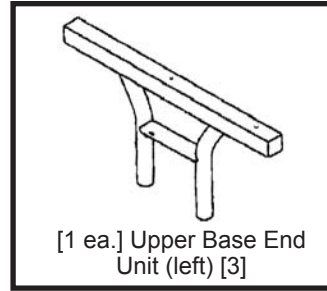
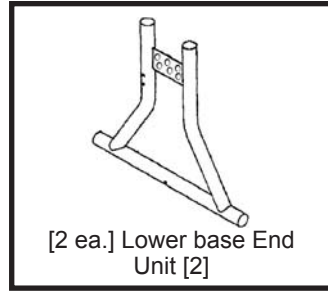
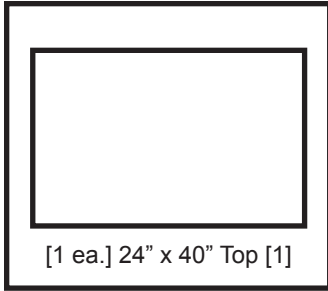

IMPORTANT

If you have difficulty assembling your U-DS90W Creation Station or need customer service assistance. Please call:
Martin Universal Design, Inc.
Customer Service Hot Line at
1-313-895-0700.

If you need additional parts, it is not necessary to contact your dealer, our Customer Service Rep. will forward them to you immediately.

List of Parts:

Qty	Part Description	Part Number
[1]	20" x 40" White Top	[1]
[2]	Lower Base End Unit	[2]
[1]	Upper Base End Unit (left)	[3]
[1]	Upper Base End Unit (right)	[4]
[1]	Base Cross Support Bar	[5]
[1]	Top Surface Cross Support	[6]
[1]	Foot Bar	[7]
[2]	Tilt Support Mechanisms	[8]
[1]	Pencil Edge	[9]
[4]	Drawer Supports	[10]
[2]	L-Bracket Top Supports	[11]
[2]	Drawer Units (3 drawers each)	[12]

Assembly Instructions:

STEP 1] Assembly Base of table

Begin by taking the [2] Lower Base End units (part #2 and attach the foot bar (part #7) and the Base Cross Support bar (part# 5) to each base end using the 1/4" x 2-1/2" Allen Bolts (part# D). Secure with Allen Wrench (part N), See FIG 1. Once the base is assembled continue by adding the [4] collars (part G) to the ends of the base, as pictured below. Complete Step 1 by inserting [2] locking castors (part J) into the front of the base end. Complete by inserting the [2] remaining castors into the rear of the base. See picture below.

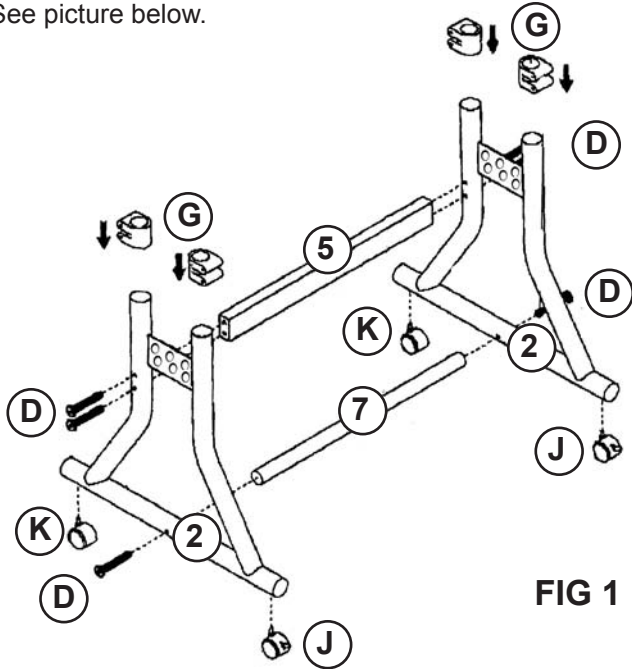

FIG 1

STEP 3] Complete Base Assembly

Take the top portion and the lower portion of the base that was just assembled. Insert the top portion into the lower portion, making sure the top ends slide into the collars that are on the lower portion of the base. Secure with the [4] male knobs (part H) tightening them into the collars. As shown below in FIG 3.

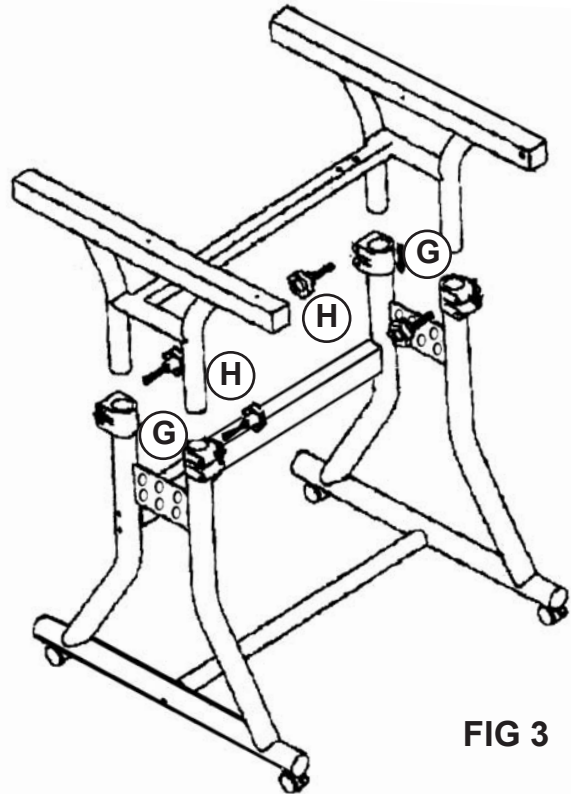

FIG 3

STEP 2] Assemble upper portion of base

Take each upper Base end (left - part #3) and (right - part #4) and attach to Top Surface Cross Support (part #6) using [2] 1/4" x 2-1/2" Allen bolts (part D). Secure with Allen Wrench See FIG 2.

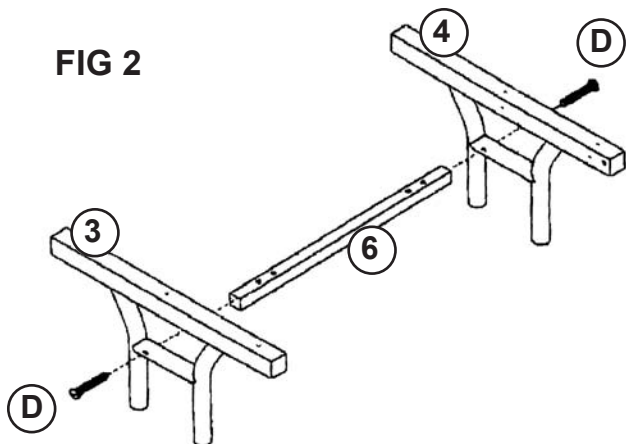

FIG 2

STEP 4] Drawer Support Assembly

Attach [2] Drawer Supports (part #10) to each set of drawers (part #12) by sliding one onto each end of the drawers making sure the hooked end is positioned as pictured below and the 2 holes are on the bottom side of the drawer unit. Secure each support using [2] M4.2 x 12mm (part F) in each support. [4] total for each drawer unit. See FIG 4.

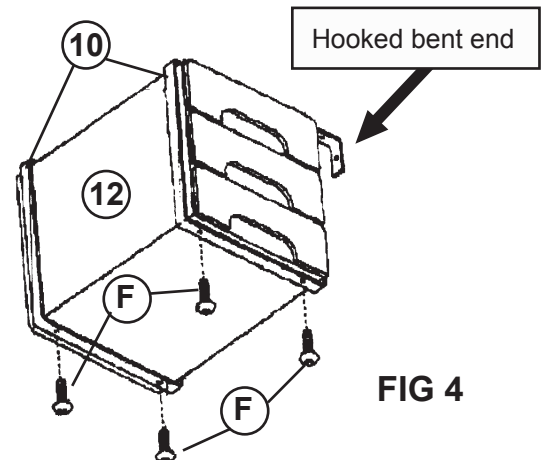

FIG 4

Assembly Instructions:

STEP 5] Attach Drawer Units to Base

Attach the drawer units to the table base as illustrated below using [4] M4.2 x 16mm screws (part E) for each drawer unit. See FIG 5 below.

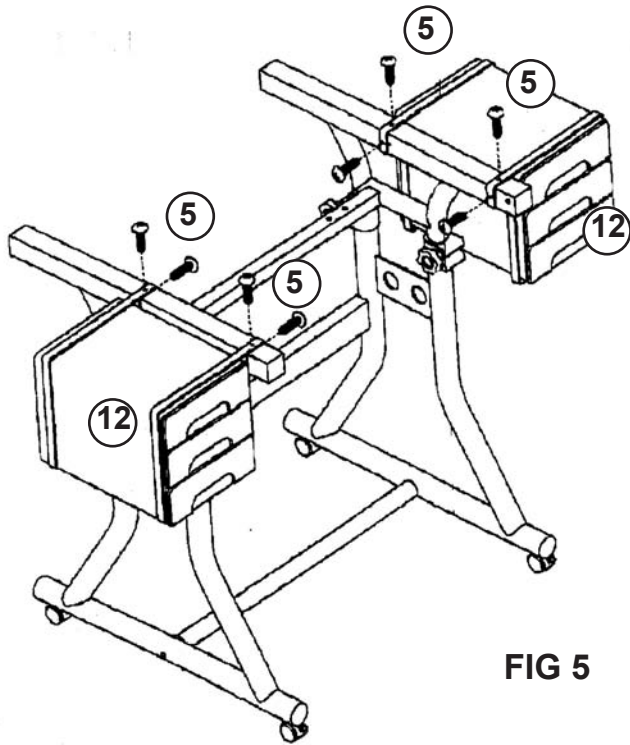

FIG 5

STEP 6] Attaching Tilt Supports to base

Attach the [2] Tilt Supports (part #8) to the Top Surface Cross Support (part #6) using [2] M6 x 13mm Allen Bolts (part A) in the upper portion of the tilt support and [2] 1/4" x 35mm Allen bolts (part C) and secure with [2] nuts (part B). SEE FIG 6.

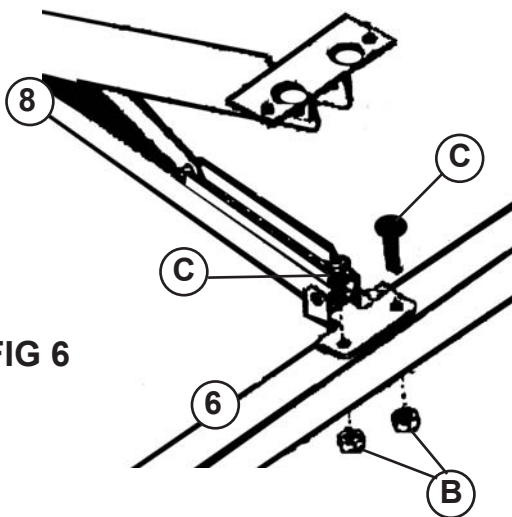
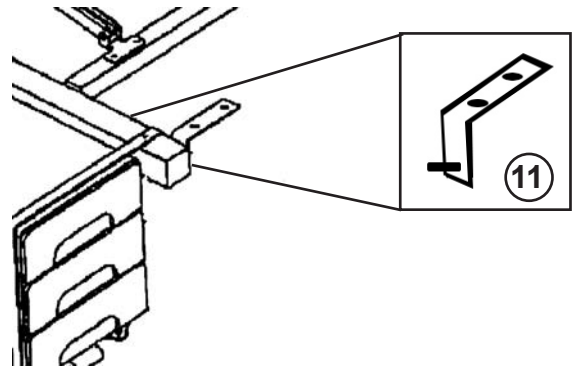

FIG 6

STEP 7] Attach L-Bracket to Base

Take the L-Bracket (part #11) and insert the pin that is attached to the L-Bracket into the hole on the inside section of the upper base end. Repeat with other side.

NOTE: This L-bracket has two holes which are used to attach to the bottom of the top with [2] Allen M6 x 13mm bolts per L-bracket. See Step 9.



STEP 8] Attaching Tilt Supports to Top

Attach the [2] Tilt Supports (part #8) to the Top (part #1) using [2] M6 x 13mm Allen Bolts (part A) into the T-Nuts found on the underside of the Table Top (part #1). Tighten with Allen Wrench. **NOTE:** This step is easier if you place the assembled base upside down onto the table top on a carpeted surface. Have [2] people help lifting and turn the base upside down.

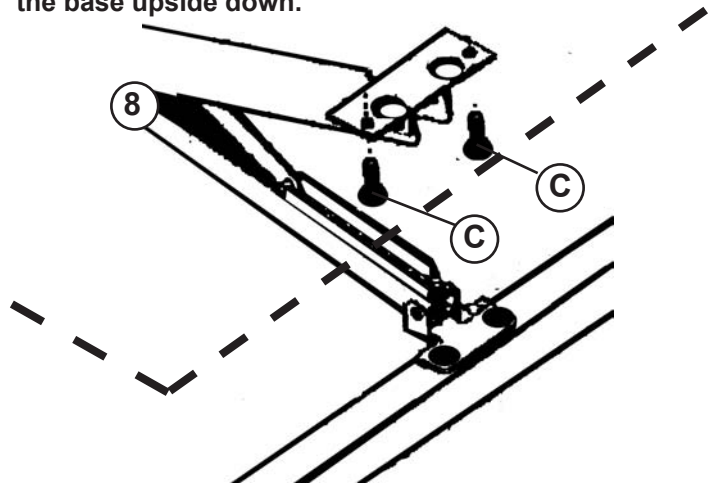

STEP 9] Attach L-Bracket to Top

Complete Top assembly by attaching L-Brackets to Top using [2] M6 x 13mm Allen Bolts and securing them into T-Nuts found on the underside of Top. Tighten with Allen Wrench.

Turn table back onto its castors for use.

Lift up on back edge of top to tilt surface.

